



**Combined Cutter/Vegetable slicer  
Combined veg slicer/cutter mixer,  
2.6 lt transp copolyester bowl**

ITEM # \_\_\_\_\_

MODEL # \_\_\_\_\_

NAME # \_\_\_\_\_

SIS # \_\_\_\_\_

AIA # \_\_\_\_\_



**602220 (DCOM26PDAU)** Combined vegetable slicer and cutter mixer 2.6 lt with transparent copolyester bowl, 1500 rpm, 3 discs included (slicer 2mm, slicer 5mm, grater 3mm) - Australia

**Short Form Specification**

Item No. \_\_\_\_\_

Vegetable slicer ensures consistent cutting results thanks to the design patented lever-pusher. Constructed in a sturdy plastic material. 1,25 liters transparent half-moon hopper. Vegetables can be fed directly into the half moon hopper, a pusher presses the vegetables against the cutting discs ensuring an even cut in minimal time. 2 small hoppers for precise cuts on long vegetables dia. 55mm or 25mm. Ideal for grating, slicing/wavy slice, julienne and dicing. A safety micro switch stops the blade when the feed hopper is opened. No-volt release system prevents accidental start of the appliance. All parts in contact with food are removable and Dishwasher safe. Single speed 1500 rpm with on/pulse/off function for simple operations. 3 discs included (slicer 2mm, slicer 5mm, grater 3mm)

**Main Features**

- Model includes 3 discs: slicer 2mm, slicer 5mm, grater 3mm.
- Combined appliance with two functions: vegetable slicer and cutter mixer.
- Equipped with vegetable slicer attachment for slicing, grating, shredding (julienne) as well as dicing and French fries cutting.
- Cutter mixer and emulsifier function included, for fast chopping, mixing, mincing, griding, liquidizing and kneading.
- Equipped with half moon hopper (1,25lt capacity) and 2 small round feed chutes: Ø 25mm and Ø 55mm, for precise slicing of long shaped vegetables.
- Uniform cuts and maximised load capacity, thanks to the design patented lever-pusher.
- Large output chute for efficient ejection. Fits up to 200mm high standard kitchen containers (like GN) under the output chute.
- Continuous feed model.
- Pulse function for quick and precise slicing and grating.
- Ergonomical frontal lever, suitable for left handed and right handed operators.
- Vegetable slicer blade stops when lever pusher is lifted for operator safety.
- Optional discs and grids available of various sizes for slicing, dicing, grating and shredding (diam. 175mm).
- Includes 2,6 liter, transparent bowl with micro-toothed blades rotor.
- Bowl/lid scraper included for uniform smooth results (emulsifying) and continuous working.
- Transparent lid, with funnel shaped hole, to add ingredients during use.
- All ingredients are processed evenly and quickly thanks to a special movement generated inside the bowl.
- Pulse function for coarse chopping.
- Easy to clean and waterproof control panel with flat on/off button and pulse function.
- All parts in contact with food are removable without the use of tools, completely dismountable and dishwasher safe.
- Productivity: up to 100 settings per service for vegetable slicer, up to 50 settings per service for cutter mixer function.

**Construction**

- Food safety assured in accordance to European directives and UK legislation. In

APPROVAL: \_\_\_\_\_



## Combined Cutter/Vegetable slicer Combined veg slicer/cutter mixer, 2.6 lt transp copolyester bowl

addition, materials in contact with food, are BPA-free.

- Product safety conform to European directives, UK legislation and international health and safety standards.
- 1 speed: 1.500 rpm.
- Power: 500 Watts.
- Bowl in BPA-free, transparent copolyester.
- Micro-toothed blades in 420 AISI stainless steel and ergonomic scraper in resistant composite material to ensure consistent mixing.
- IPX5 (IP55) waterproof, flat, touch-control panel.
- Main switch ON/OFF on the back of the appliance.
- Asynchronous industrial motor with no brushes for high reliability and quiet functioning, stainless steel motor shaft.

### Included Accessories

- 1 of TRANSPARENT LID FOR 2,6LT CUTTER MIXER BOWL PNC 650117
- 1 of 3 DISCS SET TRK1 (2MM SLICER, 5MM SLICER, 3MM GRATER) PNC 650196
- 1 of MICROTOOTHED BLADE ROTOR FOR 2.6LT CUTTER MIXER PNC 650226
- 1 of TRANSPARENT COPOLYESTER BOWL FOR 2,6 LT CUTTER MIXER PNC 650229
- 1 of SCRAPER FOR 2.6LT CUTTER MIXER BOWL PNC 650230
- 1 of EJECTOR FOR VEGETABLE SLICER PNC 650232

### Optional Accessories

- CLEANING TOOL FOR TRS-TRK-TRK210 5/8/10MM DICING GRIDS PNC 650110
- TRANSPARENT LID FOR 2,6LT CUTTER MIXER BOWL PNC 650117
- TRANSPARENT LID (WITHOUT SEALING) FOR 3,6LT CUTTER MIXER BOWL PNC 650118
- 3 DISCS SET TRK1 (2MM SLICER, 5MM SLICER, 3MM GRATER) PNC 650196
- 6 DISCS SET (2MM SLICING, 5MM SLICING, 3MM GRATING, 7MM GRATING, 10MM SLICER, 10X10MM GRID) PNC 650197
- STAINLESS STEEL GRATING DISC 2 MM (DIA. 175 MM) PNC 650198
- STAINLESS STEEL GRATING DISC 3 MM (DIA. 175 MM) PNC 650199
- STAINLESS STEEL GRATING DISC 4 MM (DIA. 175 MM) PNC 650205
- STAINLESS STEEL GRATING DISC 7 MM (DIA. 175 MM) PNC 650207
- PARMESAN DISC PNC 650208
- STAINLESS STEEL SHREDDING DISC 2 MM (DIA. 175 MM) PNC 650209
- STAINLESS STEEL SHREDDING DISC 4 MM (DIA. 175 MM) PNC 650210

- STAINLESS STEEL SHREDDING DISC 8 MM (DIA. 175 MM) - FRENCH FRIES PNC 650211
- STAINLESS STEEL SLICING DISC 1 MM (DIA. 175 MM) PNC 650213
- STAINLESS STEEL SLICING DISC 2 MM (DIA. 175 MM) PNC 650214
- STAINLESS STEEL SLICING DISC 3 MM (DIA. 175 MM) PNC 650215
- STAINLESS STEEL SLICING DISC 5 MM (DIA. 175 MM) PNC 650216
- STAINLESS STEEL SLICING DISC 6 MM (DIA. 175 MM) PNC 650217
- STAINLESS STEEL WAVY SLICING DISC 3 MM (DIA. 175 MM) PNC 650218
- STAINLESS STEEL WAVY SLICING DISC 5 MM (DIA. 175 MM) PNC 650219
- ALUMINUM SLICING DISC 8 MM (DIA. 175 MM) PNC 650220
- ALUMINUM SLICING DISC 10 MM (DIA. 175 MM) PNC 650221
- DICING GRID 8X8 (DIA 175 MM) PNC 650222
- DICING GRID 10X10 (DIA 175 MM) PNC 650223
- DICING KIT 8MM (ALUMINUM SLICER 8MM, GRID 8X8MM) - DIA. 175 MM PNC 650224
- DICING KIT 10MM (ALUMINUM SLICER 10MM, GRID 10X10 MM) - DIA. 175 MM PNC 650225
- MICROTOOTHED BLADE ROTOR FOR 2.6LT CUTTER MIXER PNC 650226
- SMOOTH BLADE ROTOR FOR 2.6LT CUTTER MIXER PNC 650227
- STAINLESS STEEL BOWL FOR 2,6 LT CUTTER MIXER PNC 650228
- TRANSPARENT COPOLYESTER BOWL FOR 2,6 LT CUTTER MIXER PNC 650229
- SCRAPER FOR 2.6LT CUTTER MIXER BOWL PNC 650230
- STAINLESS STEEL BOWL FOR 2,6LT CUTTER MIXER, MICROTOOTHED ROTOR, LID WITH SCRAPER PNC 650231
- EJECTOR FOR VEGETABLE SLICER PNC 650232
- MICROTOOTHED BLADE ROTOR FOR 3.6LT CUTTER MIXER PNC 650233
- SMOOTH BLADE ROTOR FOR 3.6LT CUTTER MIXER PNC 650234
- STAINLESS STEEL BOWL FOR 3.6LT CUTTER MIXER PNC 650235
- SCRAPER FOR 3.6LT CUTTER BOWL PNC 650236
- STAINLESS STEEL SLICING DISC 4 MM (DIA. 175 MM) PNC 650237
- TRANSPARENT BOWL FOR 2,6LT CUTTER MIXER, MICROTOOTHED ROTOR, LID WITH SCRAPER PNC 650245
- SUPPORT FOR 1 DISC-DIAM 175MM AND 205MM PNC 653632

Combined Cutter/Vegetable slicer  
Combined veg slicer/cutter mixer, 2.6 lt transp copolyester bowl

The company reserves the right to make modifications to the products without prior notice. All information correct at time of printing.





## Combined Cutter/Vegetable slicer Combined veg slicer/cutter mixer, 2.6 lt transp copolyester bowl

Front

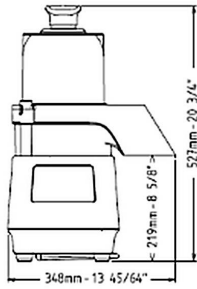

Side

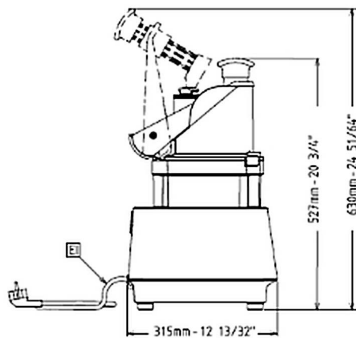

EI = Electrical inlet  
(power)

Rear side

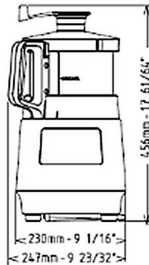

### Electric

<b>Supply voltage:</b>	220-240 V/1N ph/50 Hz
<b>Electrical power max.:</b>	0.5 kW
<b>Total Watts:</b>	0.5 kW

### Capacity:

<b>Performance (up to):</b>	0 kg/Cycle
<b>Capacity:</b>	2.6 litres

### Key Information:

<b>External dimensions, Width:</b>	348 mm
<b>External dimensions, Depth:</b>	328 mm
<b>External dimensions, Height:</b>	527 mm
<b>Shipping weight:</b>	21.1 kg
<b>Net weight (kg):</b>	14.1
<b>Cold water paste:</b>	
<b>Egg whites:</b>	



Combined Cutter/Vegetable slicer  
Combined veg slicer/cutter mixer, 2.6 lt transp copolyester bowl  
The company reserves the right to make modifications to the products  
without prior notice. All information correct at time of printing.

2026.06.16